

EAGLE OIL WATER SERIES EOW B/T



NATIONAL

HVAC MANUFACTURING COMPANY

MADE IN USA



The image shows a dark blue, rectangular oil-fired water boiler. It has a control panel on the left side with a digital display and buttons. A flexible metal duct is connected to the top of the boiler. The boiler is mounted on a base with a pump and other components. The background is a stylized American flag.

OIL-FIRED WATER BOILER

- ★ AFUE up to 87.5% - ENERGY STAR® Efficient
- ★ Beckett AFG Burners with *GeniSys* Control
- ★ *Beckett AquaSmart* Boiler Reset Control with Integral Low Water Cut-off - Meets all Federal Energy Standards
- ★ Convertible Flue Outlet (Rear Standard) (3 and 4 section boilers)
- ★ Cast Iron Block with Push Nipples and Air Separation
- ★ Swing-away Door for Easy Access
- ★ Pump and Isolating Ball Valves - Included
- ★ Insulated, Heavy Duty, Powder Coated Jacket
- ★ Limited Lifetime Warranty on Heat Exchanger



ENERGY STAR

FACTORY PACKAGED
84,000 - 273,000 BTUH INPUT

EAGLE OIL WATER SERIES EOW B/T

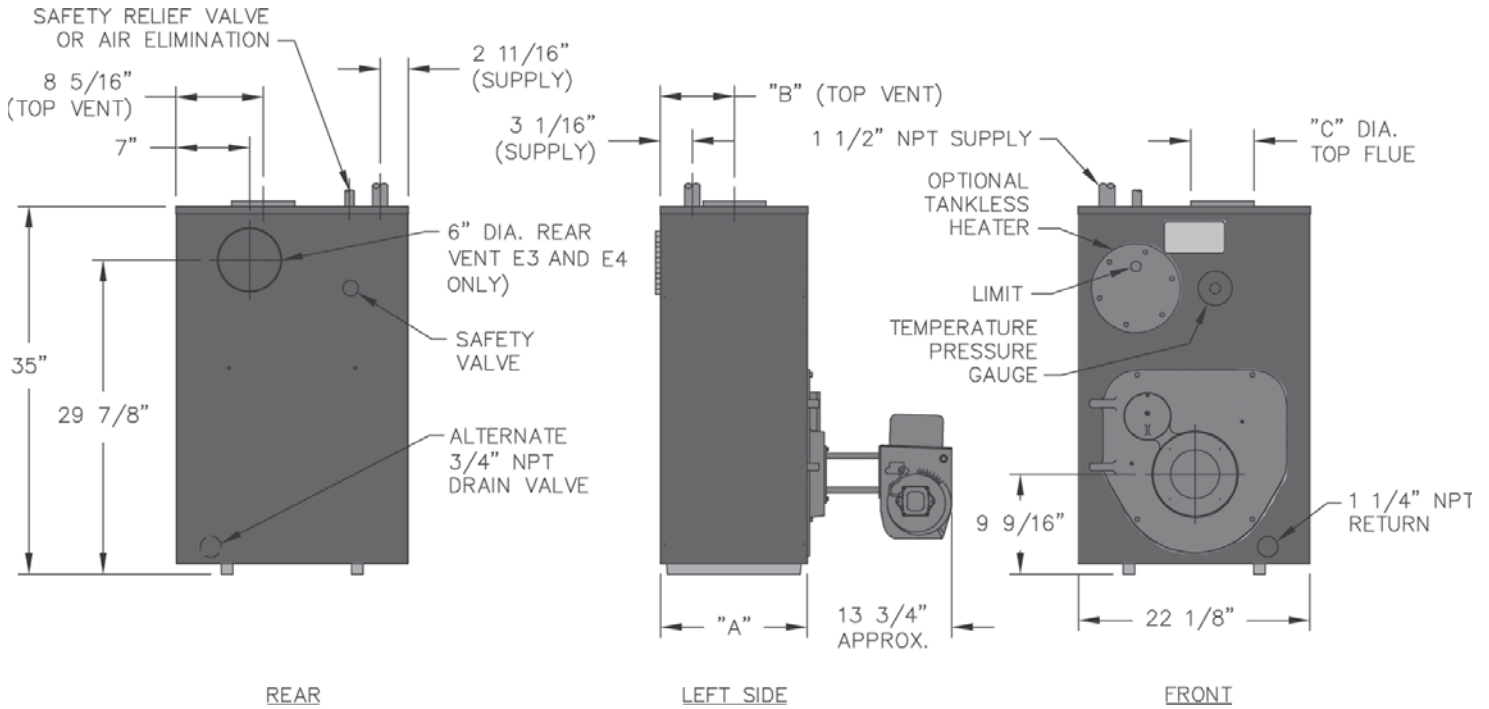

BOILER DIMENSIONS

Boiler Model Number	Jacket Depth "A"	Rear of Jacket to c/l of Vent "B"	Vent Size Diameter "C"
E3-OW-B/T	14-1/8"	7-1/16"	6"
E4-OW-B/T	18-1/8"	9-1/16"	6"
E5-OW-B/T	22-1/8"	11-1/16"	7"

CRATED DIMENSIONS & SHIPPING WEIGHTS

Boiler Model Number	Length	Width	Height	Package	
				OWB	OWT
E3-OW-B/T	35"	28-1/2"	39-3/4"	566	575
E4-OW-B/T	43"	28-1/2"	39-3/4"	694	708
E5-OW-B/T	43"	28-1/2"	39-3/4"	805	813

BOILER RATINGS

Boiler Model Number	Input		Heating Capacity ¹ , MBH	Net Ratings ³ , MBH ²	AFUE ⁴ , %	Water Content, Gallons	Minimum Stack Draft Required, in. W.C.
	GPH ¹	MBH					
E3-OW-76	0.60†	84	75	65	87.5	11.75	-.03
E3-OW-104	0.85	119	104	90	86.2	11.75	-.04
E3-OW-126	1.05	147	126	110	85.0	11.75	-.05
E4-OW-117	0.95†	133	117	102	87.0	14.75	-.03
E4-OW-151	1.25	175	151	131	85.4	14.75	-.04
E4-OW-180	1.50	210	180	156	85.1	14.75	-.05
E5-OW-212†	1.75	245	212	184	85.5	17.75	-.05
E5-OW-212†	1.95	273	235	204	85.0	17.75	-.06

Note: All models available as B/T: B=less tankless coil, and T = with Tankless coil
 † Top venting only.

‡ Nozzles for these firing rates not provided as standard equipment. Consult factory for price and availability.

- 1 Burner input based on No. 2 fuel oil with a heating value of 140,000 Btu per gallon.
- 2 Net water ratings based on an allowance of 1.15.
- 3 Consult factory before selecting a boiler for installations having unusual piping and pickup requirements, such as intermittent system operation, extensive piping systems, etc.
- 4 Heating Capacity and Annual Fuel Utilization Efficiency (AFUE) ratings are based on U.S. Government tests, with 13% CO₂ and -0.02" w.c. draft over fire. Before purchasing this appliance, read important information about its estimated annual energy consumptions or energy efficiency rating that is available from your retailer.
- 5 Chimney Size: 8" x 8" x 15 ft.



PRESENTED BY:

ORDERING INFORMATION EXAMPLE:

E3 - OW - B/T - 76
 Series/Sections | Oil Water | Model
 T-Tankless; B-Without Tankless

